

The Leading  
**Rug Makers**  
**2011**

bespoke

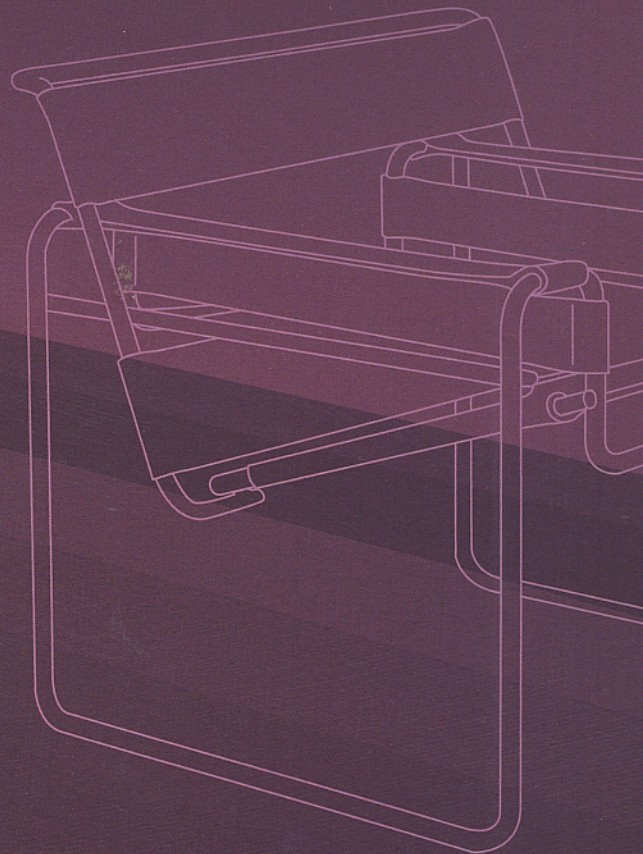

A  
**HPL**  
PROMOTION

bespoke

The Leading  
**Rug Makers**  
2011

COVER magazine is the world's leading publication for fine handmade contemporary design carpets. Just as its sister publication HALI has for over thirty years brought the best carpets and textiles to the attention of an appreciative worldwide audience, COVER highlights and reviews the most creative and innovative rugs being made today for its audience of interior designers, architects and professional buyers. In recent years we have observed the ability of some of the leading companies in the industry to make bespoke rugs to any specified sizes, designs and colours. Here we celebrate the achievements of the best ateliers and draw attention to their unique skill, creativity and quality in being able to make anything that a customer could possibly want.

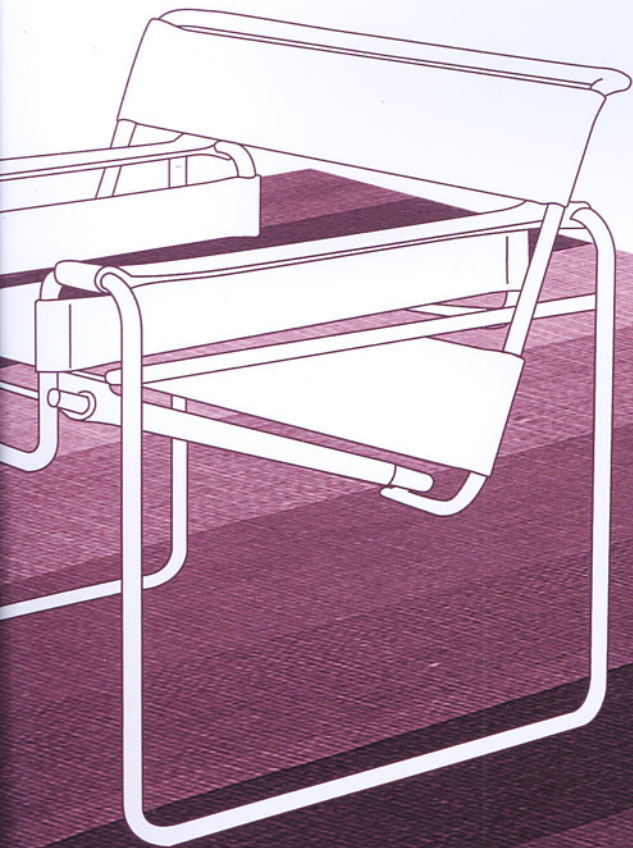

# [preface]

One of life's greatest luxuries is to have something made by hand to one's exact instructions. For me, the word bespoke immediately conjures up images of suits being made to measure in Savile Row, London or furniture being hand-crafted to exact specifications – all potent symbols of refined taste and ultimate luxury. And it is the realisation of that dream – to have something made especially for oneself – that has fired the creative instinct of some of the leading companies in the handmade rug industry over recent years.



The importance of high quality carpets within interiors has long been recognised and leading interior decorators have long known that a carpet will underpin and ground the decoration of a room in way that no other object can. In fact the ability to make carpets to a commissioned or specific design has been a defining part of court ateliers throughout history and across cultures. From the *nakkashane* of the 16th century Ottoman court, the Savonnerie carpet workshop of Louis XIII through to William Morris' carpet workshops at Merton Abbey, carpets have been made to measure by some of the world's most prestigious designers. Today the ability to have bespoke rugs made is more possible than it has ever been.

The leading rug makers in this publication are studios that excel in making carpets in both contemporary and traditional designs for some of the world's most prestigious interior design firms. The processes that each undertake in designing and making the carpets for each project are different as is the level of the client's involvement but they are united in their abilities to interpret and understand the individual qualities of each commission and reflect its subtleties. Indeed it's the ability to imbue each carpet with its own individual appropriate character that sets these companies apart from others in the industry.

I believe that reading about the projects mentioned in this second edition of our annual series of *The World's Leading Rug Makers* reveals the unprecedented levels of sophistication apparent in the high end rug industry and within these particular companies. By that, what I mean is that there are very few companies working within the interiors industry today who can truly say that they always offer the customer exactly what they want every time. The expertise in logistics, colouring, weaving and design required to make bespoke carpets are things that take years to establish, and the constant attention to detail over the course of long time frames and distances are remarkable feats in themselves but for me the skill of these companies is best seen in their rugs when viewed in the places that they have been made for, allowing these spaces to finally make complete sense.

**Ben Evans**, Editor

# Aesthetic Vision

## A commitment to what is essential in design

An historic period residence designed by architect Ehrick Rossiter in 1888 is the setting for the five rugs designed by Michael Mandapati, the owner and designer behind New York's top rug company Warp & Weft.

Mandapati worked in close collaboration with the home's owners, Eugene Kohn, principal of KPF Architects and interior designer Barbara Kohn, whose aesthetic vision propelled the project. Together they created these subtly modulated designs made in luxurious wool and silk, to work with the clean contemporary interiors, enhancing the sophisticated mix of interior architecture, fine art and modern furnishings. The success of the project illustrates well the benefits of working with a knowledgeable team.

The *Tube Plum* rug brings out the colours of the fireplace and fabrics in the room while balancing with the bright colours of the painting on the wall. *Squares Sage*, is more subtle in hue and its rectilinear form and

understated tones give good contrast to the colour and drama in the painting on the wall above.

Warp & Weft's in-house design expertise and high level of production control makes the company highly flexible in developing a perfect rug for each individual project.

We enjoy creating solutions that meet or exceed our client's expectations.

*Michael Mandapati*



*Squares Sage* rug by Warp & Weft



*Tube Plum* rug by Warp & Weft

### WARP & WEFT

145 Madison Avenue  
New York, NY 10016, USA  
phone: +1 (212) 481 4949  
e-mail: [info@warpandweft.com](mailto:info@warpandweft.com)  
[www.warpandweft.com](http://www.warpandweft.com)